

## Precise and Simple Pallet Weighing Rugged, Fast and Easy to Use



### Ergonomic Full Function Handle

- Easy to Lift
- Easy to Move
- Easy to Weigh



### Turning Wheel

- Effortless steering
- Easy ride over uneven surfaces



### Terminal

- Large 7-digit LCD display
- Low power consumption and automatic shut off
- Five standard keys plus two free definable function keys

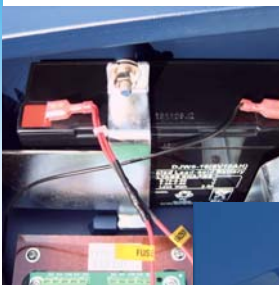

### Battery

- 6V DC, 10Ah
- Operating time: 95 hours
- Charging time: 8-12h



### BTA231 Pallet Truck Scale

#### Precise and Simple Pallet Weighing

The mobile battery-powered solution for pallet weighing in one easy step. The BTA231 Pallet Truck Scale is the ideal solution for fast and precise mobile weighing in industrial and warehousing applications.

Technical data

## BTA231 Pallet Truck Scale

### Display

7 digit bright LCD 40mm high

### Capacity

2,000 kg

### Precision

0.1% maximum deviation from measuring range

### Readability (approved)

2 kg

### Key Pad

6 function tactile keypad

### Battery with Charger

- 6VDC, 10Ah
- 95 hours operating time
- 8~12 hours charging time

### Pallet Truck Construction

Mild steel

### Load Cell Capacity

1 ton x 4, 2mV/V

### Lifting Height

115 mm

### Fork Height

- Lowered: 75 mm
- Raised: 190 mm

### Fork Length

1,150 mm

### Single Fork Width

180 mm

### Operating Temperature

- -10°C to +40°C
- <85% humidity

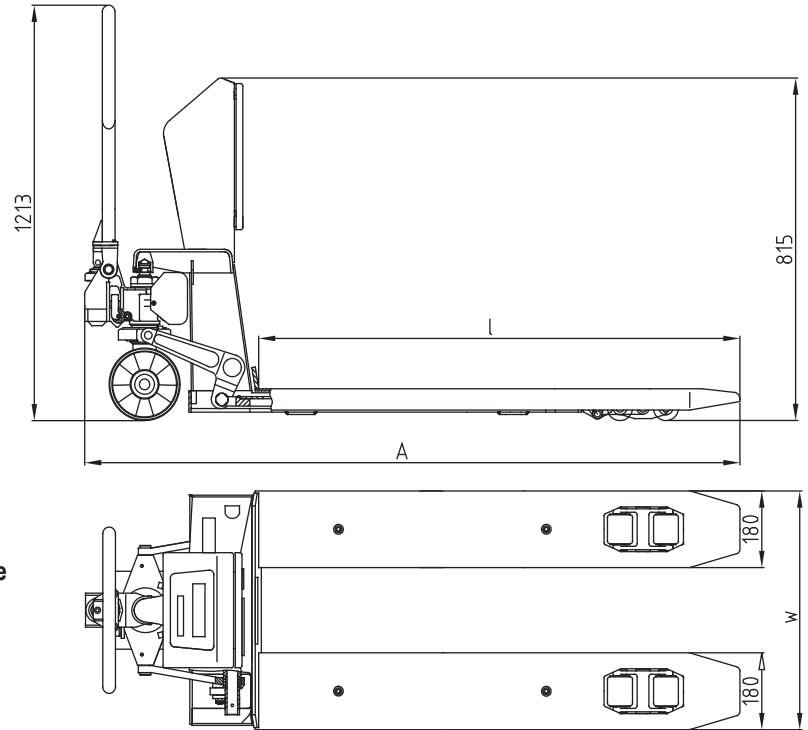

### Pallet Truck Scale

Item	Model	Capacity [t]	Resolution [kg]	Fork Size(w x l) [mm]	Length A [mm]	Shipping Information		
						Length[mm]	Width[mm]	Height[mm]
30084520	BTA231-555A	2	2	555 x 1150	1570	1620	600	1000
30084521	BTA231-690A	2	2	690 x 1220	1640	1700	730	1000



### METTLER TOLEDO

#### Industry/Retail

Add: 111 West Tai Hu Road, Xinbei District,  
Changzhou, Jiangsu  
Tel: 0519-86642040  
Fax: 0519-86641991  
E-mail: ad@mt.com

#### Laboratory/Process/Packaging Industry

Add: 589 Gui Ping Road, Shanghai  
Tel: 021-64850435  
Fax: 021-64853351  
E-mail: ad@mt.com

Subject to technical changes  
Printed in P. R. China 2014/08

[www.mt.com](http://www.mt.com)

For more information